

SXWA

VERSION

N 1750 rpm

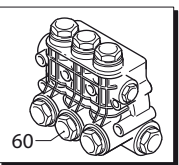
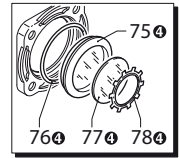
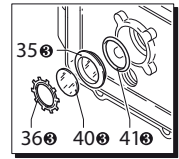
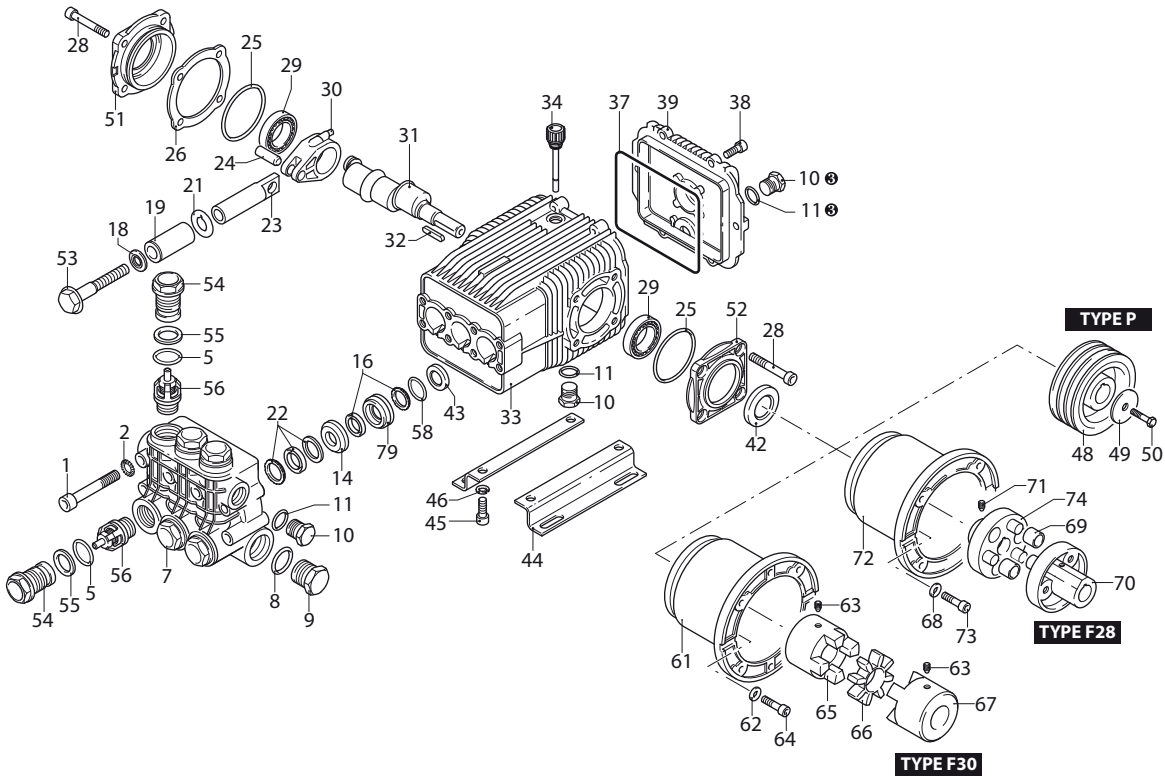

UN002611-AV

KIT RICAMBI / PART KITS

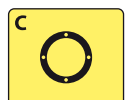
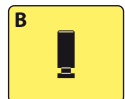
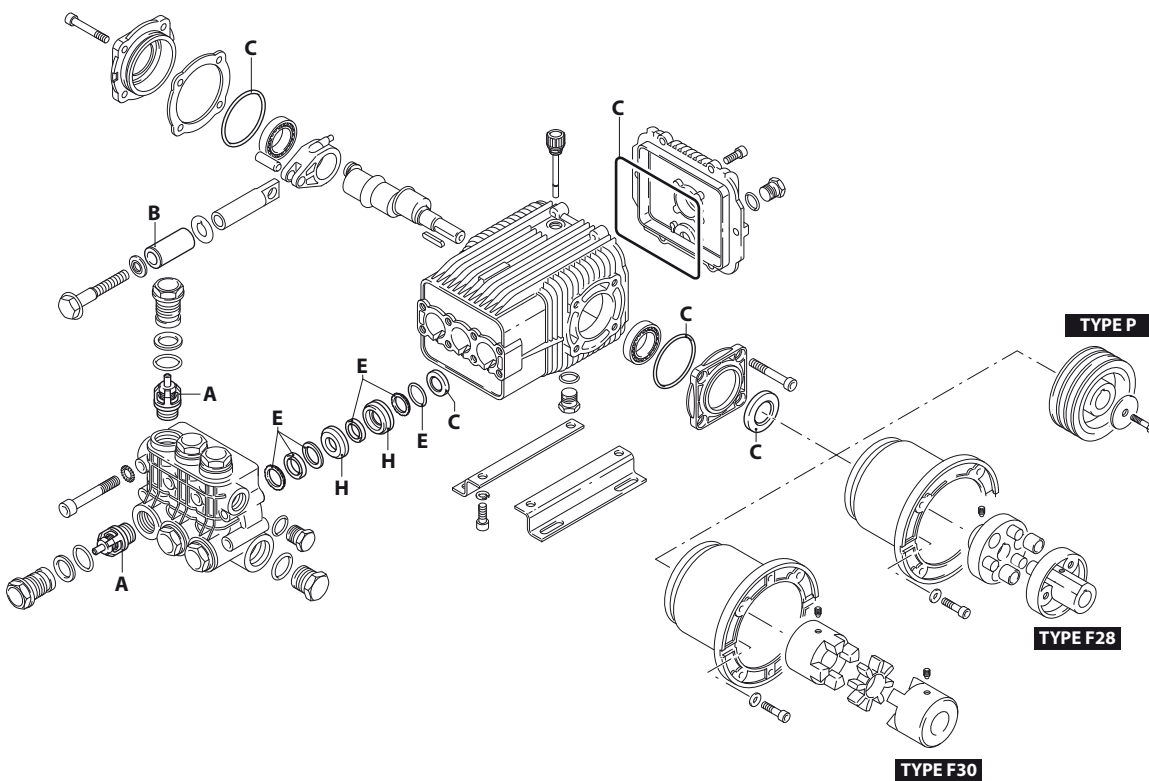

UN002612-AV

SXWA

VERSION
N

MODELLO - MODEL:

4 G50 5.5 G50 7 G50



Pos.	Cod. Part n°	Denominazione	Description	Q.tà Q.ty	Note Vedi / See	Pos.	Cod. Part n°	Denominazione	Description	Q.tà Q.ty	Note Vedi / See
1	1940260	Vite TCEI M 10x80	Screw	8	⊗ 50 Nm	48	1940290	Puleggia	Pulley	1	4 B
2	650530	Rosetta	Washer	8		49	780230	Rondella	Washer	1	
5	880830	OR ø 15,54x2,62	O-Ring	6		50	780060	Vite TCEI M 6x25	Screw	1	
7	1942530	Testa pompa	Pump head	1		51	1949011	Coperchio lat. compl.	Compl. side cover	1	
8	180101	OR ø 17,5x2	O-Ring	1		52	1941240	Supporto aperto	Open bearing sup.	1	
9	820361	Tappo 1/2" G	Plug	1		53	1941640	Vite fiss. pistone	Piston-fixing screw	3	⊗ 7 Nm
10	1980740	Tappo 3/8" G	Plug	3	⊗	54	1940940	Tappo valvola	Plug	6	⊗ 60 Nm
11	740290	OR ø 14x1,78	O-Ring	3	⊗	55	1941070	Anello antiestr.	Ring	6	
14	1942470	Guida pistone ant.	Front piston guide	3		56	1949051	Valvola completa	Complete valve	6	
16	1942690	Guarnizione	Gasket	3		58	820490	OR ø 34,65x1,78	O-Ring	3	
18	1340600	Rondella	Washer	3		60	1949204	Prem.testa	Head pre-assembly	1	■ □ ▲
19	1941020	Pistone	Piston	3		61	1383080	Flangia motori B3/B14	El. motor flange	1	B3/B14
21	1383190	Disco separatore	Spacer	3		62	390311	Rondella Øi 8,5	Washer	4	
22	1942700	Guarnizione	Gasket	3		63	1380180	Grano M 6x10	Grub screw	2	
23	1940960	Pistone di guida	Guiding piston	3		64	620610	Vite TCEI M 8x30	Screw	4	
24	1940060	Spinotto	Con rod pin	3		65	1383100	Semigiunto pompa	Pump coupling	1	
25	1941380	OR ø 66,34x2,62	O-Ring	2		66	1940850	Anello elastico	Ring	1	
26	1941390	Spessore 0,05 mm	0,05 mm shim	1		67	1383090	Semigiunto motore	Motor coupling	1	
	1941400	Spessore 0,10 mm	0,10 mm shim	1		68	390311	Rondella Øi 8,5	Washer	4	
	1941410	Spessore 0,19 mm	0,19 mm shim	1		69	1321670	Boccola	Bushing	6	
	1941420	Spessore 0,25 mm	0,25 mm shim	1		70	1380340	Semigiunto motore	Motor coupling	1	
28	850370	Vite TCEI M 8x16	Screw	8	⊗ 24,5 Nm	71	1380180	Grano M 6x10	Grub screw	2	
29	1140410	Cuscinetto	Bearing	2		72	1940890	Flangia motori B3/B14	El. motor flange	1	B3/B14
30	1940050	Biella	Conrod	3		73	620610	Vite TCEI M 8x30	Screw	4	
31	1940520	Albero eccentrico	Crank shaft	1	■	74	1940870	Semigiunto pompa	Pump coupling	1	
	1940170	Albero eccentrico	Crank shaft	1	□	75	1941270	Livello olio	Oil indicator	1	⊗
	1940970	Albero eccentrico	Crank shaft	1	▲	76	100410	OR Ø 34,6x2,62	O-Ring	1	⊗
32	650250	Linguetta 8x7x40	Key	1		77	1941260	Disco di contrasto	Disc	1	⊗
33	1941330	Corpo pompa	Pump housing	1		78	1941290	Anello elastico	Snap ring	1	⊗
34	1140370	Tappo olio	Plug	1		79	1942480	Guida pistone post.	Rear piston guide	3	
35	1260250	Livello olio	Oil indicator	1	⊗						
36	1260430	Anello elastico	Snap ring	1	⊗						
37	1940410	OR ø 132x3	O-Ring	1							
38	1200430	Vite TCEI M 6x16	Screw	6							
39	1949010	Coperchio post. compl.	Complete cover	1							
40	1780690	Disco di contrasto	Disc	1	⊗						
41	1140450	OR Ø 20,24x2,62	O-Ring	1	⊗						
42	820680	Anello tenuta	Seal	1							
43	1940560	Anello tenuta	Seal	3							
44	1940370	Piede pompa	Base	2	Optional						
45	1940380	Vite TCEI M 10x18	Screw	4	Optional						
46	200231	Rosetta	Washer	4	Optional						

KIT RICAMBI - PART KITS

A=KIT 2871 valvole valves		B=KIT 2872 pistoni pistons		C=KIT 2873 tenute olio oil seals		D=KIT 2874 tenute acqua water seals	
Pos.	Q.ty	Pos.	Q.ty	Pos.	Q.ty	Pos.	Q.ty
56	6	19	3	25	2	16	3
				37	1	22	3
				42	1	58	3
				43	3		

G=KIT 42120 guida pistoni pistons guide							
Pos.	Q.ty	Pos.	Q.ty	Pos.	Q.ty	Pos.	Q.ty
14	3						
79	3						

SIMBOLOGIA - SYMBOLS

■ Per / For SXWA 4 G50	□ Per / For SXWA 5.5 G50	▲ Per / For SXWA 7 G50
⊗ Compreso nel cod. 1949010 / Part of part n° 1949010		
⊕ Compreso nel cod. 1949011 / Part of part n° 1949011		
⊗ = Coppia serraggio (Tolleranza +0 / -10% Nm)		
⊕ = Torque wrench (Allowance +0 / -10% Nm)		